



IMMAGINE INDICATIVA PRODOTTO

7265.0085

Product file

Type	Compact
Mounting	Wall
Code	BEWS302LA50P11
Range	BEWS
Version	Saddle
Noise	35.3 dBA 10 m
Condensation	Air
Net weight	93 kg
PED	0
Defrost	Hot gas
Expansion	Valve
Application	LBP
Refrigerant	R290

Dimensions

Width L	671 mm
Depth P	975 mm
Height H	828 mm

Absorptions

Power consumption	1300 W
Current consumption	7.1 A

Condenser

Fan-motors no.	1
Diameter	300 mm
Air flow	1200 m ³ /h

Unit cooler

Fan-motors no.	2
Diameter	200 mm
Air flow	1000 m ³ /h
Air throw	6.5 m

Compressor

Type	Hermetic
Compressors no.	2
Brand	EMBRACO
Voltage	230/1/50
Displacement	22.4 cm ³

Technical data - BEWS302LA50P11 - 7265.0085

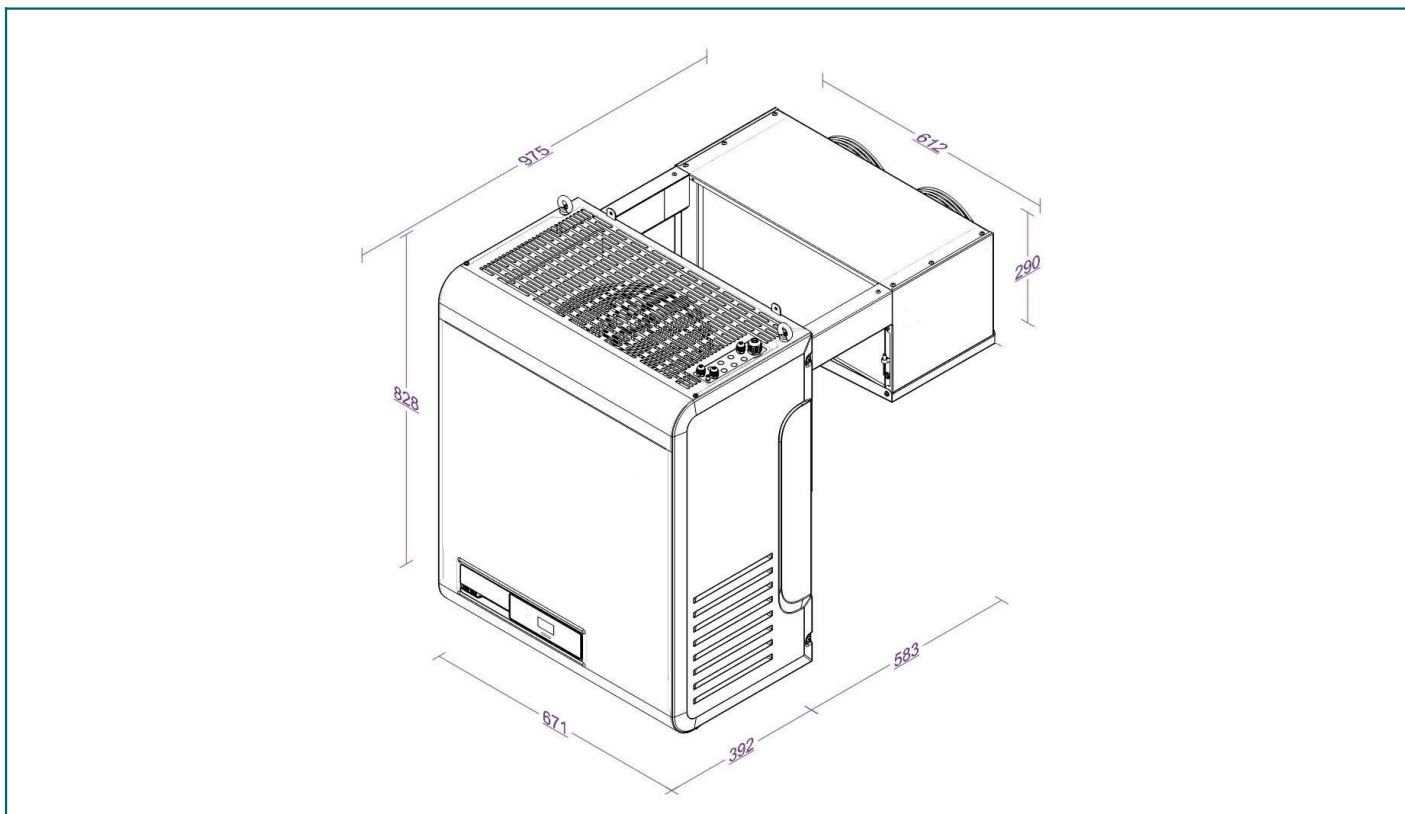

Technical data - BEWS302LA50P11 - 7265.0085

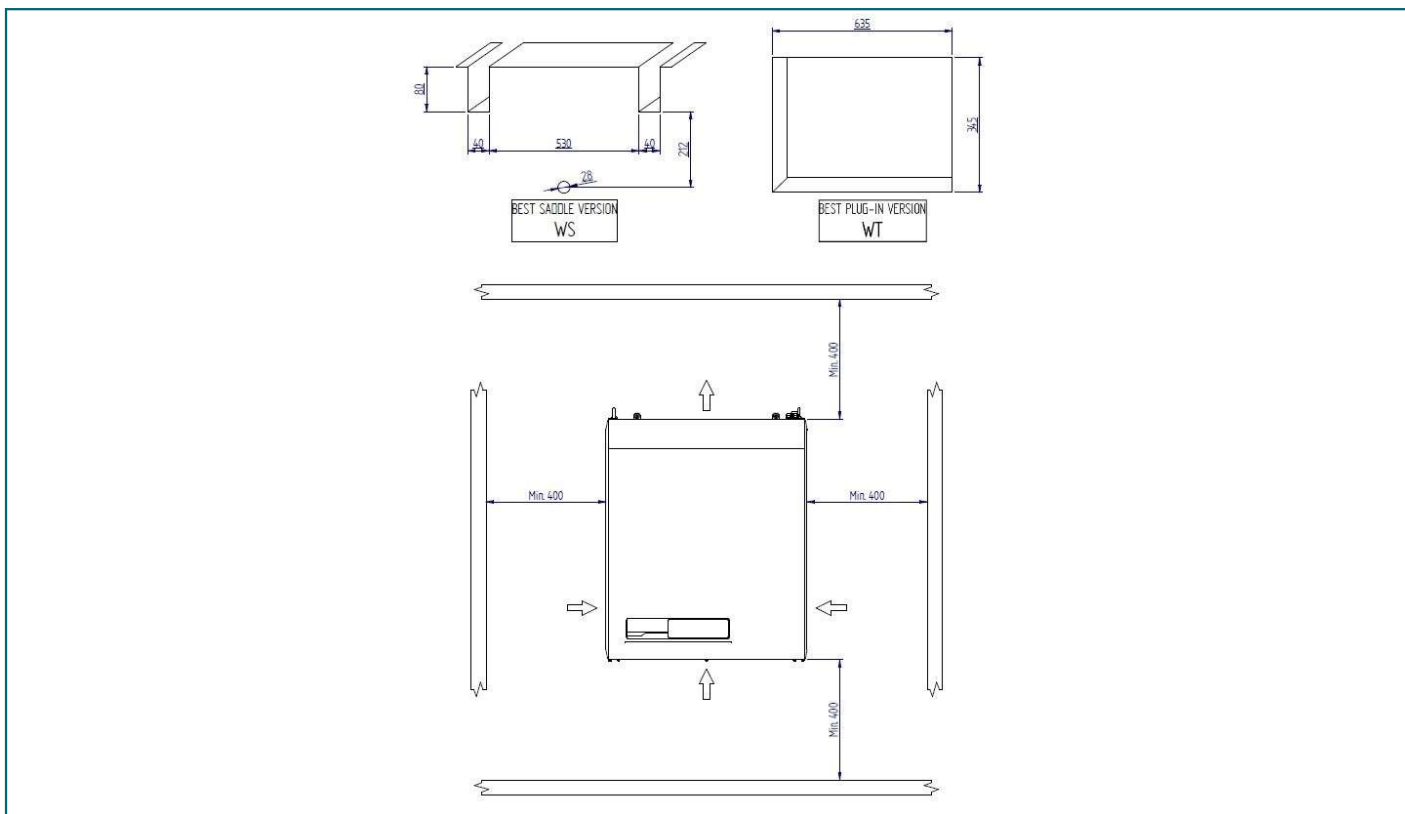

Refrigerating capacity table - BEWS302LA50P11 - 7265.0085 - Refrigerant: R290

TA \ Tcella	-25°C	-20°C	-15°C
25°C	1408 (15.5 m³)	1678 (25.6 m³)	1979 (41.5 m³)
32°C	1283 (10 m³)	1539 (17.4 m³)	1824 (28.3 m³)
43°C	1091 (5.6 m³)	1325 (8.4 m³)	1584 (13.2 m³)

Values referred to :

Suction gas : +20°C

Subcooling : 0K

Superheat : 100%

Compressor absorption :

Te -5°C (HBP); Tcond +50°C

Te -10°C (MBP); Tcond +50°C

Te -30°C (LBP); Tcond +50°C



IMMAGINE INDICATIVA PRODOTTO

MAIN COMPONENTS MECHANICAL PART

- Hermetic compressors with thermal motor protection
- Condenser with Ø5mm tubes with internal spiral rifling
- Evaporator with Ø5/16" tubes with internal spiral rifling
- Electronic fan-motors on both condenser and evaporator
- Mechanical thermostat valve supplied standard across entire range
- Hot gas defrosting
- Evaporating water tray
- R290 refrigerant charge ≤ 150g per circuit

CONTROL CIRCUIT and ELECTRIC PART

- Safety pressure switch on high pressure side
- High and low pressure probes
- Door micro wired with cable L= 2.5
- Door heater cable on LT models (L = 2.5m)
- LED cold room light with cable L= 5m
- Power cable L= 2.5 m with wired electrical plug
- Industrial Plug (2P+E or 3P+N+E) 16 A
- Industrial Plug (2P+E) 32 A only on BEWx352MA80P11 and BEWx352LA60P11

ELECTRONIC CONTROL

- Rivolution: programmable electronic control with software developed by Rivacold
- Smart Defrost and Leak Detector functions
- Bluetooth connectivity
- APP to manage and control packaged system functions
- Connection cable for BMS (RTU Modbus Protocol)
- LED display with new graphics and white backlight
- Backlit touch keyboard

STRUCTURE

- Self-supporting frame in galvanized metal sheet
- Easily removable housing to allow rapid access to the components in case of inspection or maintenance
- Installation kit complete with screws and washers to secure the packaged system to the wall of the coldroom and sealing putty in strips for insulation
- Plug-in thickness 100 mm for MT models and 150 mm for BT models (WT models)

OPTIONAL ITEMS

- Epoxy powder finish on all metal sheets
- Plug-in insulation kits supplied separately for saddle models (WS): 100mm, 150mm, 200mm
- Catephoresis treatment of exchangers (Condenser + Evaporator)
- Extension cable kits L=5m and L=10m (coldroom light cable, door heater cable, micro-switch cable)
- Remote control panel kits with 5m cable and 10m cable
- Presetting for Master & Slave (cable L=5m)
- Alarm cable kit L=5m
- IoT – Remote monitoring and control service (Wi-fi – 2G)